

JWGP / JWDP Series

Glycol Make-up Systems
For Closed Loop Heating & Cooling Systems



Glycol Make-up Systems

APPLICATION

1. The JWGP / JWDP glycol make-up systems are designed to maintain minimum system pressure levels. They are completely automatic and operate as needed to add water or water-glycol solution to a closed loop heating, chilled water, snowmelt, or radiant heating system.
2. A pressure switch controls the flow of the glycol solution to the closed loop system. When the system pressure drops to the cut in pressure setting, the pump will start. As the pump runs and feeds the glycol solution to the system, pressure in the system will increase. When the system pressure reaches the cut-out pressure setting, the pump shuts off.

OPERATION

1. The pressure regulating valve (PRV), located on the discharge line, controls the flow of glycol to the closed loop system. When the closed loop system pressure falls to the set pressure of the PRV, the valve opens, allowing the pressurized glycol solution to flow from the expansion tank to the closed loop system. The PRV is factory set to operate between 12 to 15 PSI.
2. As the glycol solution flows from the pressurized tank into the system, the pressure upstream of the PRV will begin to decrease. When the pressure falls to the cut-in pressure setting, the pump starts running.
3. As the make-up system feeds the glycol solution to the closed loop system, the pressure in the loop begins to increase. When the loop pressure rises above the set pressure of the PRV, the valve closes, allowing the system to refill the expansion tank.
4. As the expansion tank fills, the pressure in the make-up system increases. When the pressure rises to the cut-out pressure switch setting, the pump shuts off.
5. The cycle will repeat each time the pressure in the closed loop system falls to the PRV set point.
6. A low level alarm switch is provided on the glycol holding tank. When the glycol solution level falls below the location of the switch, the make-up system shuts down. A fault indicator light and audible alarm horn will activate. Refilling the glycol in the holding tank automatically resets the alarm and indicator light.

INSTALLATION INSTRUCTIONS

1. Locate the Glycol Make-up System for ease of inspection, maintenance, and service. Secondary containment may be required to catch leaks or spills.
2. Level the steel base and fasten it to the mounting surface using properly sized anchor bolts.
3. Connect the ½" NPT system discharge fitting to the closed-loop system piping.
4. Check the system interconnection for leakage.
5. Refer to the wiring and control panel diagrams prior to installing the electrical connections. A 120 VAC power supply with a dedicated ground wire is required.
6. Verify the correct settings for the pressure switch. The pressure switch is factory set to operate at 40 PSI (cut-in) and 60 PSI (cut-out).
7. Check the setting on the pressure relief valve. The pressure relief valve is factory set to operate at 125 PSI.

PRESSURE SWITCH OPERATION

1. The pressure switch has two operating points – one on rising pressure and one on falling pressure. The operating point on rising pressure is the cut-out setting, and the operating point on falling pressure is the cut-in setting.
2. The differential is the difference between the cut-in setting and the cut-out setting.
3. The range indicates the pressure limits for the pressure operating settings. The range is referenced to the operating point on rising pressure. The differential is subtracted from the cut-out pressure setting. During normal operation, the system pressure should not exceed the upper limit of the range.
4. Maximum allowable pressure is the highest pressure to which the switch can be subjected without causing a change in operating characteristics, shift in settings, or damage to the unit.
5. Pressure surges may occur in a system during start-up. Surges are not normally detrimental to the life of a switch if the surge is within the maximum allowable pressure rating of the switch. Diaphragm actuated switches should not be subject to more than 10 surges per day. More frequent surges will greatly reduce the life of the diaphragm.

INSTRUCTION MANUAL

Form 900M

SETTING THE PRESSURE SWITCH

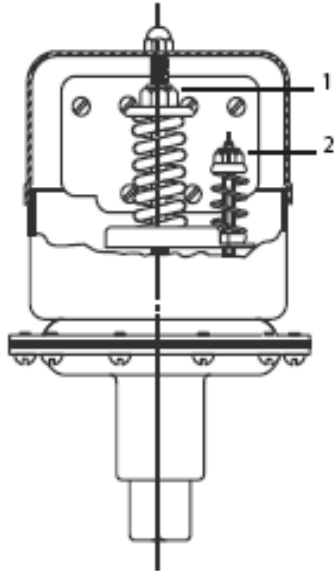

1. When setting the pressure switch, adjust the switching point on rising pressure (cut-out) first and then adjust the point on falling pressure (cut-in).
2. **Switching point on falling pressure:** set the cut-in pressure by adjusting screw-nut 1.
3. **Switching point on rising pressure:** set the cut-out pressure by adjusting screw-nut 2.

PRESSURE SWITCH REFERENCES

1. Adjustable range for the pump cut-in setting: 40 – 170 PSIG
2. Adjustable range for the pump cut-out setting: 65 – 200 PSIG
3. Differential pressure: 20 – 40 PSIG
4. Maximum permissible pressure: 200 PSIG

SPARE PARTS LIST

| DESCRIPTION | PART NUMBER |
|----------------------|-------------|
| Expansion tank | 100099150 |
| Pump | 100099115 |
| Pressure switch | 11099120 |
| Pressure gauge | 060563006 |
| Level switch | 100099130 |
| Pressure regulator | 100099085 |
| Tank, 30 gallon | 100199068 |
| Tank lid, 30 gallon | 100199078 |
| Tank, 55 gallon | 100199070 |
| Tank lid, 55 gallon | 100199080 |
| Tank, 100 gallon | 100199072 |
| Tank lid, 100 gallon | 100199082 |

Glycol Make-up Systems

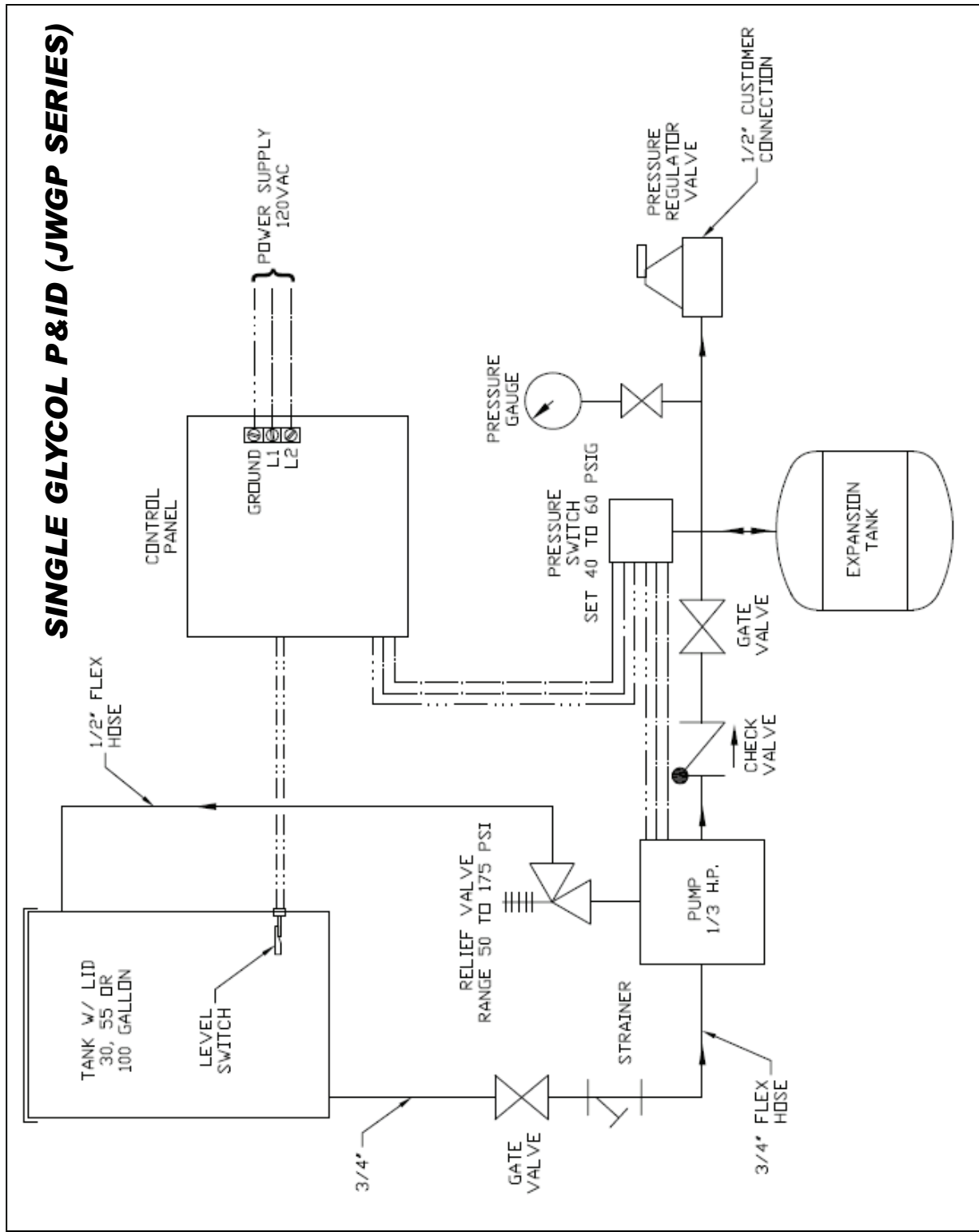

INSTRUCTION MANUAL

Form 900M

DUAL GLYCOL P&ID (JWDP SERIES)

NOTES:

1. ALL PIPE 1/2" SCH 40 UNLESS NOTED OTHERWISE.

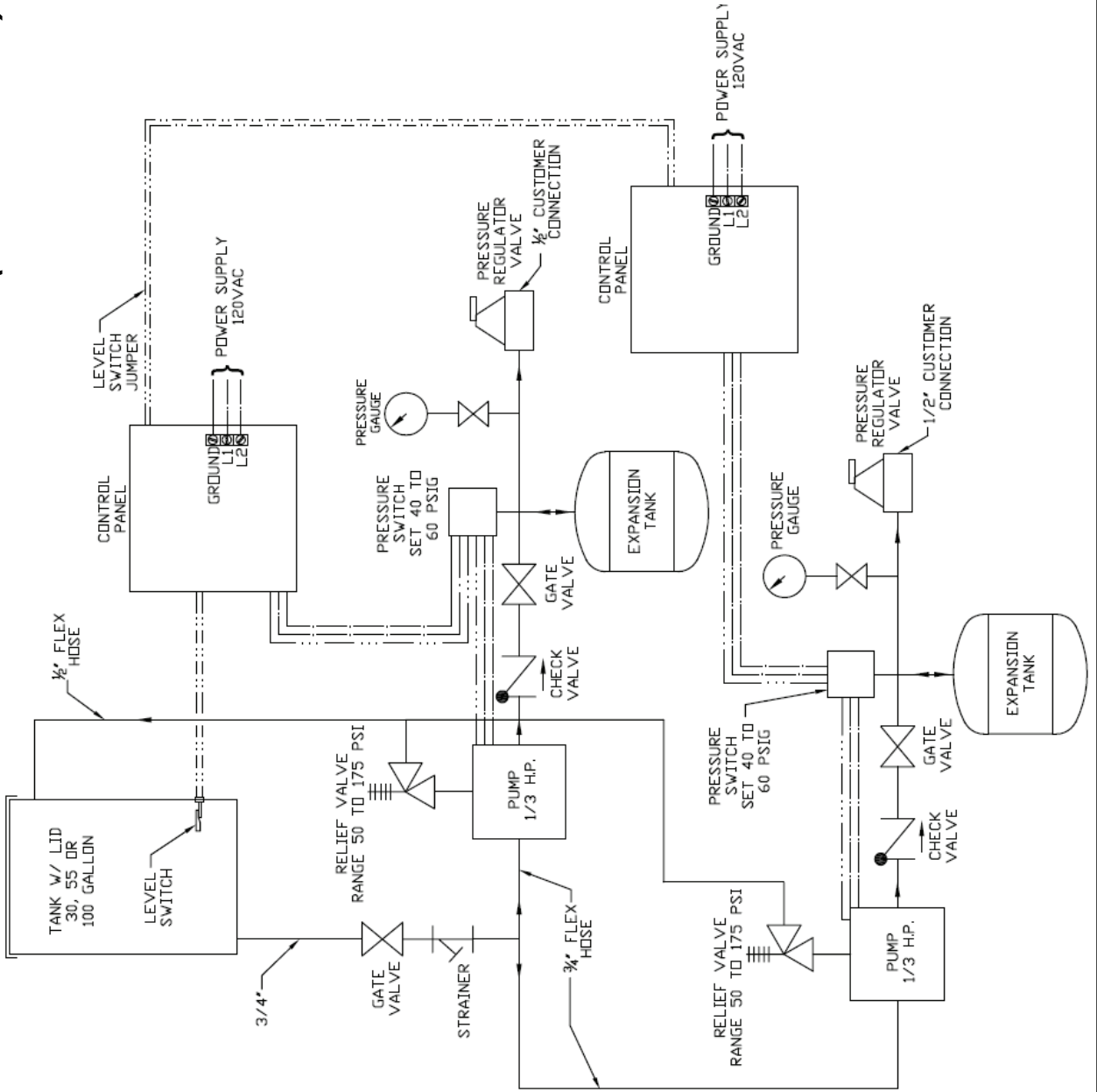

Glycol Make-up Systems

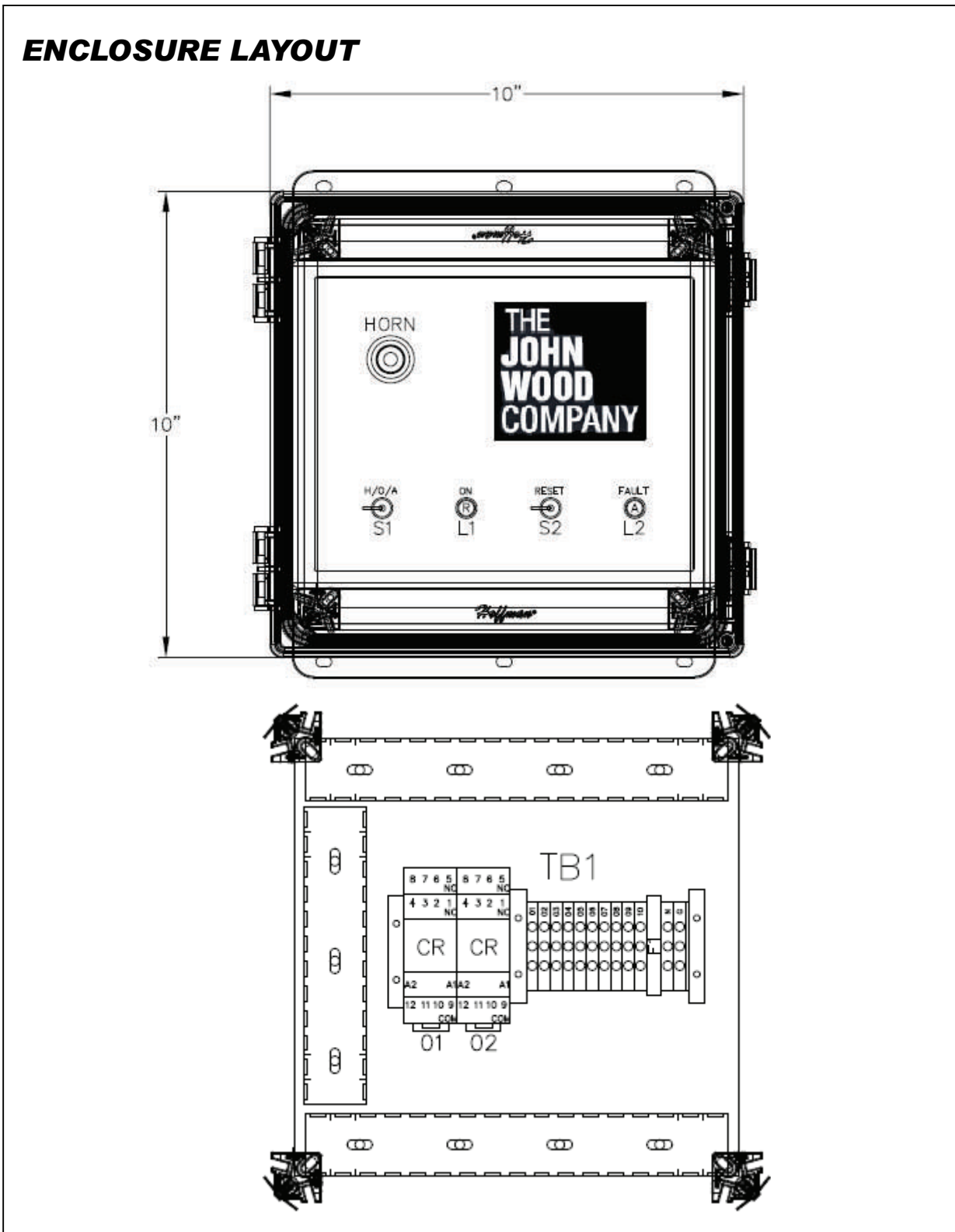

INSTRUCTION MANUAL

Form 900M

CONTROL SCHEMATIC

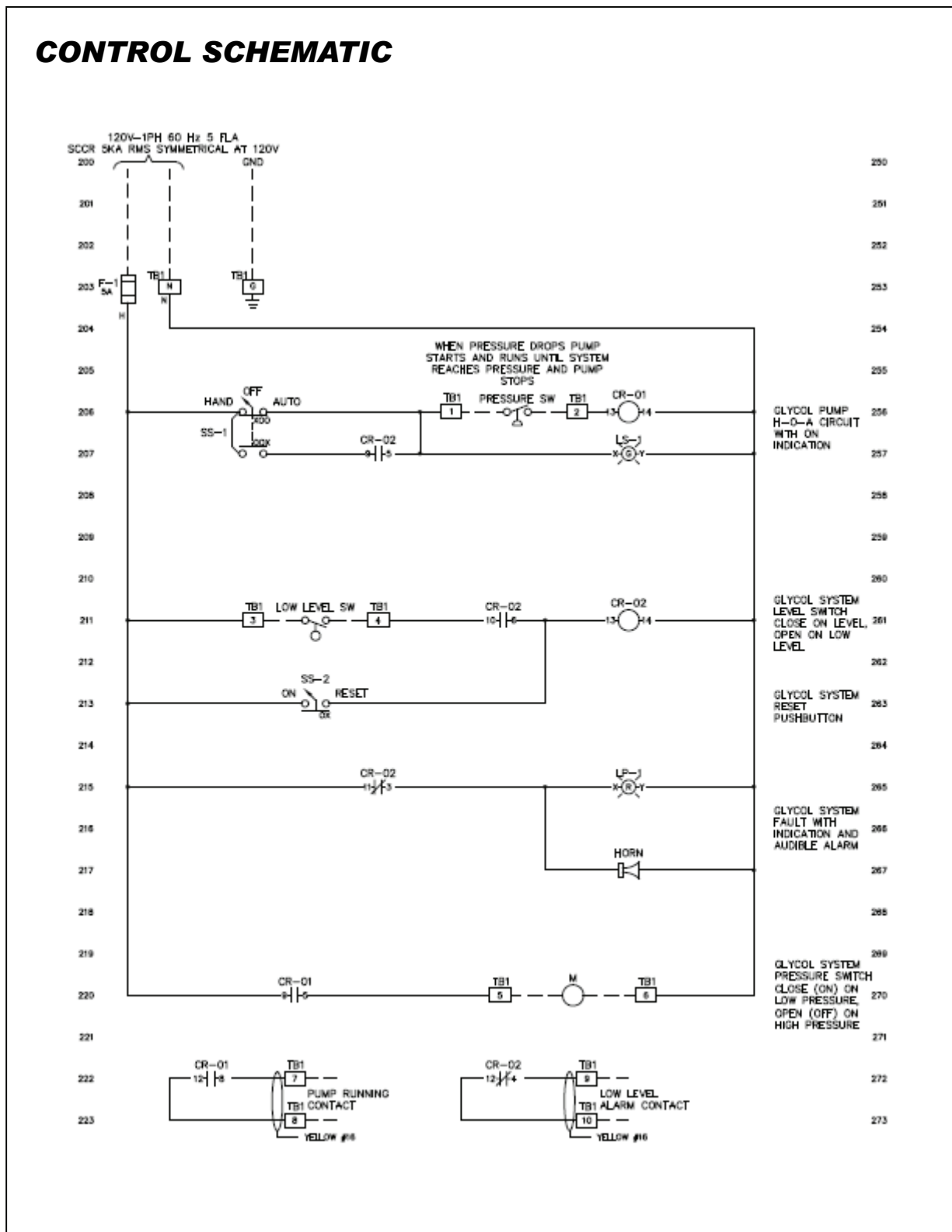

THE JOHN WOOD COMPANY
 AN ALCO INDUSTRIES COMPANY
 98 Highland Avenue, Oaks, PA 19456
 T 610-666-1220 | 800-537-5581
 F 610-666-0193