

## JOPR Series

# ASME Type I Bladder Tanks with Bottom Connection For 80 to 3963 Gallon Sizes

### GENERAL INSTRUCTIONS

1. Type I replaceable bladder tanks with bottom connections are designed for vertical installation.
2. In order to properly check or modify the air charge pressure on the tank after the system is filled with water, shut-off and drain valves must be installed in the piping connected to the tank.
3. The drain valve is used to flush the system and to drain the water out of the tank prior to changing the air charge pressure.
4. An automatic air vent must be installed in the piping to the expansion tank to vent off accumulated air.
5. A pressure gauge must be installed to properly monitor the system pressure at the tank.
6. A minimum overhead clearance of approximately 18" is required to remove and replace the bladder if necessary.

### INSTALLATION INSTRUCTIONS

1. Note the location of the NPT system connection and the Schrader type air charge valve.

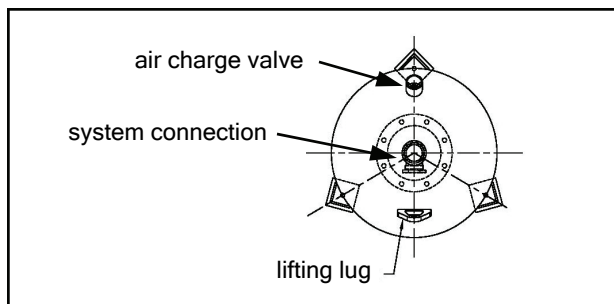

2. Inspect the connections and the tank for signs of damage that may have occurred during shipping.
3. Locate the nameplate and verify that the tank is suitable for the operating conditions of the system. The marked maximum allowable working pressure (MAWP) must be greater than or equal to the maximum system operating pressure. The marked maximum design temperature must be greater than or equal to the maximum system operating temperature.

### OPERATING / MAINTENANCE INSTRUCTIONS

1. All Type I bladder tanks are shipped from the factory with a precharge air pressure of 12 PSIG. Use an accurate pressure gauge to check the air charge pressure prior to installation. The pressure should be within  $\pm 3$  PSI depending on the ambient temperature. Notify the factory immediately if a loss of pressure has occurred.
2. Prior to installation, set the desired air charge pressure. The air charge pressure in the tank is typically set 2 PSI below the pressure switch pump cut-in pressure or 10% to 20% below the system pressure for a surge application. Note that the air charge pressure for the standard Type I tank must not exceed the maximum allowable working pressure of the tank.
3. Charge the tank with nitrogen or with oil-free compressed air. Check the pressure frequently during the filling process.
4. **IMPORTANT:** To accurately set the air charge pressure, the tank must be charged with air or nitrogen at ambient temperature.
5. **WARNING** Excessive pressure may cause the tank to fail. Failure to follow these instructions may result in serious personal injury and property damage.
6. Connect the tank to the system. Each piping connection must include a lock shield gate valve and union to allow the tank to be isolated from the system or safely removed if necessary.
7. **WARNING** Do not loosen the holddown nuts on the bottom cover plate. Loosening the holddown nuts will cause a loss of air charge pressure.
8. Check the air charge pressure before filling the system with water. Verify that the air charge pressure is correct for the system.
9. Leak check all connections on the tank, including the top fitting or cover plate and the bottom cover plate (including studs, nuts, and seal) with a suitable leak detector solution.
10. When filling the system with water, all valves in the piping leading to the tank must be open to ensure that the air in the bladder is displaced by the system water.
11. If the air charge pressure needs to be changed after the system is filled with water, follow these steps:
  - a. Shut off the water source.
  - b. Close the lock shield valve in the system piping.

# ASME TYPE I

## OPERATING / MAINTENANCE INSTRUCTIONS

- c. Open the drain valve in the system piping and allow the water to drain from the tank.
  - d. Check the air charge pressure with an accurate pressure gauge and charge the tank to the desired set pressure.
  - e. Close the drain valve, open the lock shield valve, and turn on the system.
12. During normal system operation, follow standard preventative maintenance procedures.
  13. **IMPORTANT:** Periodically check the tank for signs of leakage or corrosion and monitor the air charge pressure to ensure safe and efficient operation of the tank and system.
  14. Loss of the air charge pressure is typically an indication that either the Schrader air charge valve may be leaking or the bladder may be leaking.

## SCHRADER VALVE INSPECTION AND REPLACEMENT

1. If the tank fails to hold the air charge pressure, the Schrader valve may need to be replaced.
2. Prepare the tank for service. Refer to items 11a through 11d in the operating instructions starting on Page 1.
3. **⚠ WARNING** Do not remove the valve core stem until the pressure in the expansion tank reaches zero. Depress the valve stem and slowly vent off the air pressure. Failure to follow these instructions may result in serious personal injury and property damage.
4. Replace the Schrader valve core and follow the instructions for properly charging the tank as outlined on Page 1.
5. Leak check all connections on the tank, including the cover plate seal, with a suitable leak detector solution.

## BLADDER REPLACEMENT INSTRUCTIONS

1. Depress the valve core stem on the air charge valve.
2. If a combination of water and air escapes, the bladder needs to be replaced.
3. Prepare the tank for service.
4. Close the lock shield valve in the piping to the tank.
5. Open the drain valve and allow the water to drain from the bladder.
6. Depress the valve stem on the Schrader valve to vent off the air pressure. Remove the valve core to bleed off the remaining air charge.
7. Disconnect the system piping from the tank connection and allow any remaining fluid to drain out of the bladder.
8. Using small increments, loosen the nuts on the bottom cover plate to allow any remaining air to be vented slowly.
9. Remove the bottom cover plate.

10. Remove the top NPT fitting or flanged access cover. The bladder is attached to a U-bolt with a swivel type connector assembly (see Figure 1).
11. Prior to disconnecting the bladder from the U-bolt, fasten a rope to the swivel connector on the top of the bladder.
12. **IMPORTANT:** Maintain tension on the rope and slowly lower the bladder while pulling the bladder through the bottom opening.
13. Wash down the inside of the tank if necessary.
14. Dry out the inside of the tank.
15. Examine the inside of the tank. Clean out any remaining dirt and remove any rust blisters. If the bottom mounting flange area is corroded, the tank will not seal properly. Replace the tank if necessary.
16. Fasten the rope to the swivel connector on the top of the new bladder.
17. Fold the new bladder lengthwise and insert it through the tank opening. Use the rope to pull the bladder into the tank.
18. Using water from a spray bottle, lubricate the bladder to make it easier to fit through the opening. Avoid catching the bladder on the studs. Do not use sharp objects to push the bladder into the tank.
19. Position the bladder collar over the studs.
20. Inspect the top fitting and bottom cover plate and remove any residue that may prevent proper sealing.
21. Attach the swivel connector to the U-bolt in the top fitting.
22. Reinstall the top fitting and the bottom cover plate.
23. Tighten the nuts in a crossing pattern using approximately 20% increments of torque. For cover plates with 12 or fewer studs, use a total of 70 to 80 ft-lbs. of torque. For cover plates with 16 studs, use a total of 200 to 230 ft-lbs. of torque. (see Figure 2).
24. Install the Schrader valve core stem and charge the tank to the system fill pressure. Refer to items 2 through 8 in the operating instructions on Page 1.
25. Use a leak detector solution or soapy water to leak check all connections including the Schrader valve, system connection, studs and nuts, and the cover plate seals.
26. Connect the tank to the system.

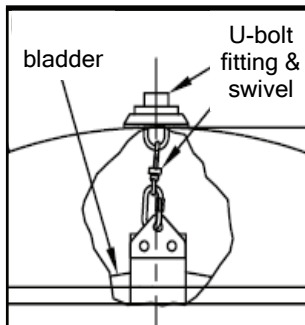

Figure 1



Figure 2